

CARE AND MAINTENANCE

1. Regular washing down of the exterior surface will help prolong the lustre of the painted finish.
2. Painted fountains that become dull due to prolonged exposure to direct sunlight can be restored with an appropriate surface polish.
3. To maintain the exterior of the fountain carefully remove any loose surface deposits with a wet sponge. Use a soft (non abrasive) brush and dilute a solution of mild detergent (eg. PH-neutral liquid hand washing detergent in warm water (DO NOT use solvents) to remove dust, salt and other deposits. Rinse thoroughly with clean fresh water to remove residues. To remove any Tea Staining on Stainless Steel surfaces we recommend Drifter Hull cleaner and stain remover.
4. Do not use any solvents on the surface as this will adversely affect the longevity of the painted finish.
5. Surface scratches and inconsistencies can be touched up using Dulux touch up paint. Most colours can be matched.
6. We recommend the use of anti-seize paste on all external fixing bolts to maintain ease of access over long periods of time.
7. Check the fountain internal connections, water flow and all external access screws and fixing bolts regularly (every 3mths) to ensure they are tight.
8. In high debris areas (parks, children's playgrounds etc) where there may be sand or bark or a lot of leaf litter that may be placed in to the basin, check regularly and remove debris to prevent blocking of the basin or the waste outlet pipe.
9. After any interruption to the water supply, always flush the lines prior to reconnection to the fountain to prevent debris entering the valve.

WARRANTY

All Urban Fountains and Furniture outdoor drinking fountains are covered by a 2 year manufacturers guarantee against faulty materials and workmanship under normal wear and tear conditions.

All fountains are date stamped at the time of despatch.

This warranty will only apply under the following conditions:

- The fountain was installed in accordance with our installation instructions that are supplied with every fountain.
- The fountain was installed by a licensed plumber
- The water lines have been thoroughly flushed prior to connection to the fountain
- The fountain has not been tampered with or repaired in any way without obtaining prior approval from our factory specialists first.
- The fountain has been serviced and maintained as per our supplied instructions.

ATTENTION PLUMBERS

This fountain uses "Push In Fittings". Failure to release these fittings correctly will result in leakage.

These quick release fittings allow instant connection and disconnection without the use of spanners.

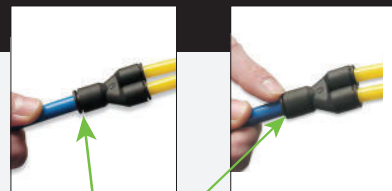

Push outer ring in to release tube from fitting

urban + Fountains Furniture

Drinking Fountains

Models: CF430-B, CF430

urban + Fountains Furniture

INSTALLATION, OPERATION AND MAINTENANCE INSTRUCTIONS

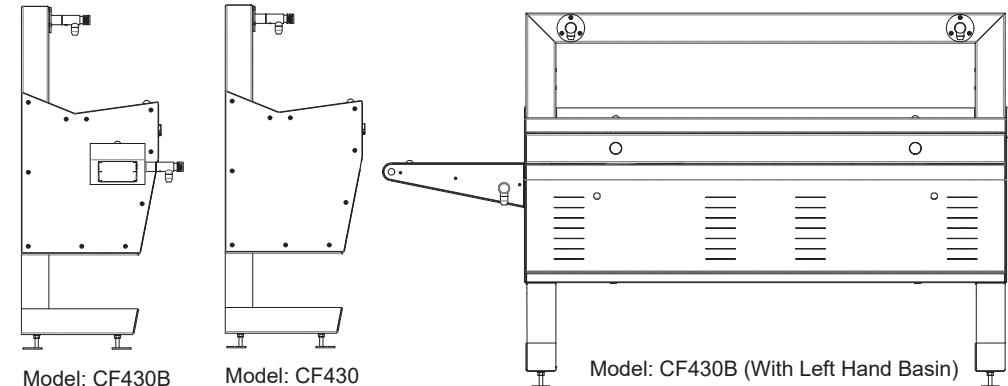

Model: CF430B

Model: CF430

Model: CF430B (With Left Hand Basin)

SPECIFICATIONS

- ▶ 1/2" bsb water inlet (15mm)
- ▶ 40mm waste outlet
- ▶ Maximum Temperature: 40°C
- ▶ Maximum Water Pressure: 700 kpa
- ▶ Complies with WMTS-105 Technical Specification: Appliances - Beverage dispensers and icemakers
- ▶ Complies with AS/NZS 4020 Testing of products in contact with drinking water

2 year
warranty



Lead Free

WM-080042
WMTS-105

CUSTOMER SERVICE

 **07 3382 7372**

 **office@urbanff.com.au**

 **07 3287 5598**

 **www.urbanff.com.au**



INSTALLATION

STOP! Please read all supplied information before installation.

- All UrbanFF Fountains must be installed by a qualified plumber and Qualified Electrician in accordance with National plumbing and drainage code AS/NZS 3500.1 and AS/NZS 3500.2 and Electrical AS3000 Regulations and any other local authority codes.
- Floor or wall mounted option. If floor mounted Install on level ground if possible. For wall mounted - IMPORTANT – Wall is to be assessed by structural engineer prior to installation to ensure load bearing is possible.
- 240V single phase power is required along with mains water supply and waste outlet drainage.
- Before Installation FLUSH ALL EXTERNAL LINES before connecting to fountain.
- PLEASE NOTE: No Trap is supplied inside the fountain. Trap to be fitted externally by plumber.
- Remove the fountain from the packaging preventing scratching and damage to the body of unit
- Installation under shade preferable.
- Please refer to provided installation drawings below for unit mounting details.
- Connect the 40mm waste outlet pipe to the waste water connection.
- If you have not flushed the external water inlet pipes – do it now! Flushing the water inlet pipes from the mains supply before connecting to fountain will help prevent blockage by any debris that may be in the external pipes.
- Connect water supply to ½” BSP inlet.
- Test the bubbler and bottle filler by activating the button.
- Incorrect installation will affect fountain performance. Urban Fountains and Furniture will not be responsible for defects that arise from incorrect installation.
- All fountains have been checked for leaks as part of our quality assurance program and some droplets of water may be evident inside the packaging and/or unit. This is perfectly normal.
- Refer to trouble shooting guide if you experience any problems.
- Check all connections and waste piping to ensure they are tight & secure.

* PLEASE REFER TO ANNEX A

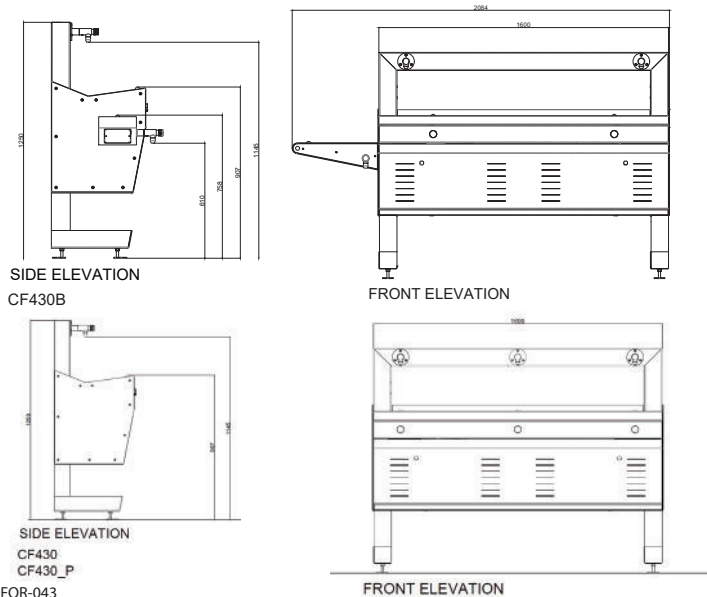

SIDE ELEVATION
CF430B

FRONT ELEVATION

SIDE ELEVATION
CF430
CF430_P

FRONT ELEVATION

TROUBLESHOOTING

| | |
|--|--|
| There is restricted or no water flow? | Check the inlet lines for kinks in the tubing. Ensure the water supply valve is fully open. Check the water pressure regulator is open. |
| The water continues to drip / run after shutting off? | The most common cause of water not shutting off is a leaking valve and is due to the lines not being flushed adequately and debris getting in to the valve through the inlet and sitting on the rubber seals. To check the valve it will need to be removed. Please contact this office for details instructions to ensure this is done correctly. |
| The water flow is shooting over the top of the basin or is not high enough and trickling over the nozzle? | The water pressure is too high / low and needs to be adjusted via the water flow regulator so it flows in to the catchment area of the basin. |
| Leaking from the internal connections? | Check that they have been installed correctly. (all fountains are leak tested prior to leaving the factory). Have the push in fittings been pulled? (see instructions on how to connect and disconnect push in fittings). Is the water inlet connection tight? |

SPARE PARTS

| | | | | | |
|------------------------------|-----------------|---------------|-------------------------------|-----------------|---------------------|
| 8mm "Y" Fitting | reorder code: → | PL1003 | Maintenance Tap | reorder code: → | PL1034 |
| ¼" Legris Fitting | reorder code: → | PL1030 | Bottle Filler | reorder code: → | CM1125 |
| 1/4 x 90° Fitting | reorder code: → | ELB ¼" x 90 | Urban Push tap with Paw print | reorder code: → | CM1125-DT |
| 3/8 x 90° Fitting | reorder code: → | ELB 3/8" x 90 | Enware Valve | reorder code: → | DFX.A280.VALVE.ASSY |
| 8mm Straight Male -¼" BSPT | reorder code: → | PL1011 | Urban "T" Valve | reorder code: → | CM1110 |
| 8mm Straight Male -3/8" BSPT | reorder code: → | PL1035 | Pressure Control Valve | reorder code: → | PL1114 |
| 5/16" Hose-Blue | reorder code: → | PL1108 | 15mm Mini Ball Valve | reorder code: → | PL1019 |
| Self Returning Tap | reorder code: → | PL1008 | Stop tap BUB268 | reorder code: → | PL1031 |
| 8mm Stem-¼" BSPT | reorder code: → | PL1000 | Urban Bubbler | reorder code: → | CM1125-MG |
| 8mm Stem-3/8" BSPT | reorder code: → | PL1001 | 8mm Equal Elbow | reorder code: → | PL1002 |
| ½" Hollow Brass All Thread | reorder code: → | PL1007 | | | |

urban + Fountains Furniture

* ANNEX A

GENERAL NOTES:

FOR OPTIMUM PERFORMANCE OF FOUNTAIN PLEASE ENSURE THAT THE FOUNTAIN IS LEVELED USING THE ADJUSTABLE FEET, OR MOUNTED ON THE WALL PARALLEL WITH THE FLOOR

BRICK WALL / BARRIER/ PARTITION
PLEASE NOTE:
PRODUCT CAN BE FLOOR AND WALL MOUNTED

COUNCIL WATER SUPPLY TO CONNECT TO WATER FILTER BY MEANS OF 1/2" BSP CONNECTION

CROSS SECTION

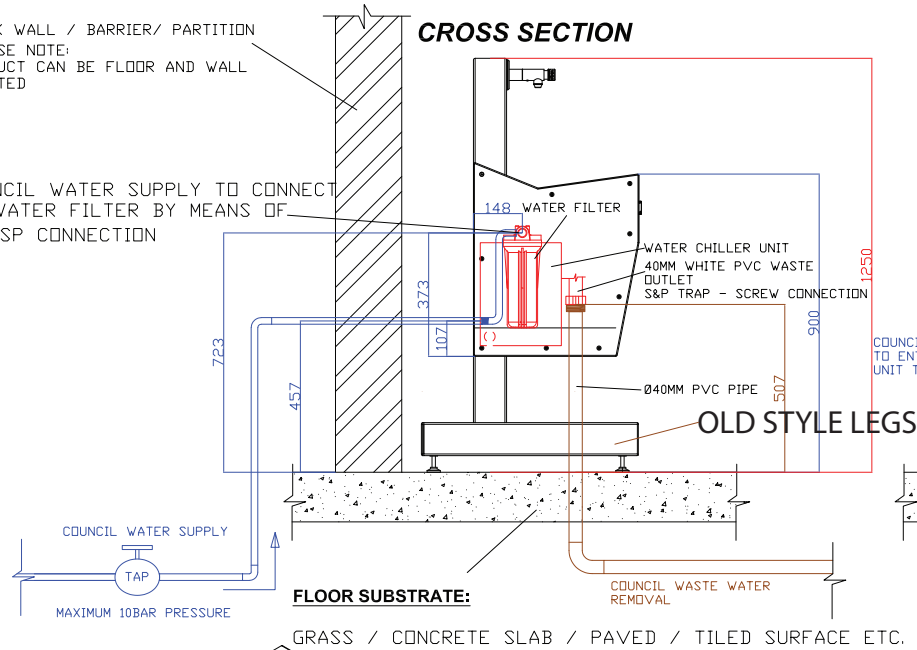

FRONT ELEVATION

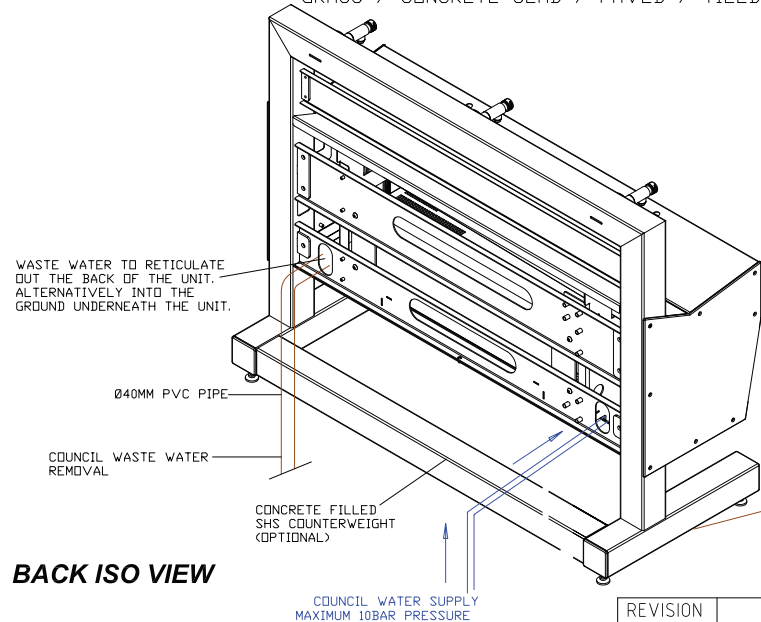
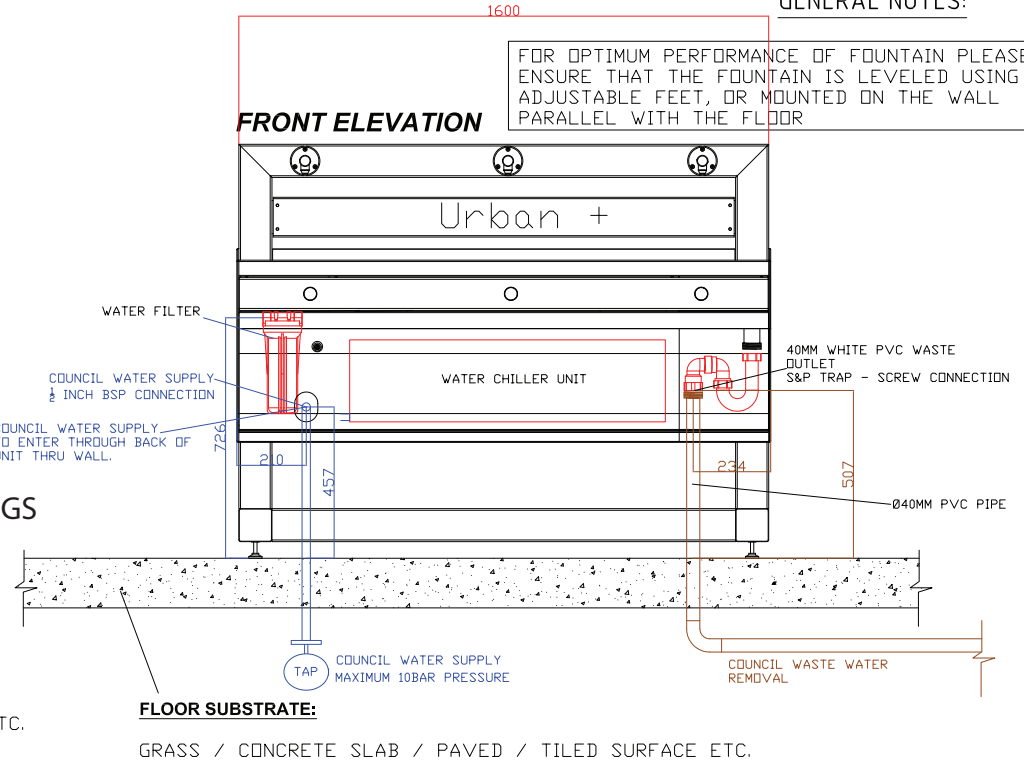

BACK ISO VIEW

PLEASE NOTE

THIS DRAWING IS INDICATIVE OF THE SITUATION ON SITE. CONDITIONS ON SITE MAY DIFFER TO INFORMATION STIPULATED HEREIN.

OLD STYLE LEGS. PLEASE CHECK ACTUAL PRODUCT.

urban+

URBAN FOUNTAINS AND FURNITURE PTY LTD.
5 TELFORD CIRCUIT
YATALA, QUEENSLAND 4207
PH: (07) 3382 7372
FX: (07) 3287 5598
WWW.URBANFF.COM.AU

COPYRIGHT DISCLAIMER

This drawing, and all information illustrated herein are subject to copyright. This drawing may not be copied in part or whole, without any prior written consent from Urban Fountains and Furniture Pty Ltd.

DO NOT SCALE DWG. IF IN DOUBT ASK.

UNITS OF MEASURE
ALL DIMENSIONS ARE IN MILLIMETERS U.O.N. MM

| | |
|------------------------|--------------------|
| DRAWN BY N.FERGUSON | DATE 24/01/2022 |
| SCALE 1:5 | SHEET/S 1 OF 1 |

DRAWING TITLE
CF400-INSTALLATION INFO

| | |
|---------------------------------|----------------|
| DRAWING NUMBER CF400-INSTALL | REVISION 00 |
|---------------------------------|----------------|

| REVISION | DESCRIPTION | DRAWN BY | DATE |
|----------|------------------------|------------|------------|
| 00 | ISSUED FOR INFORMATION | N.FERGUSON | 24/10/2022 |