

urban⁺

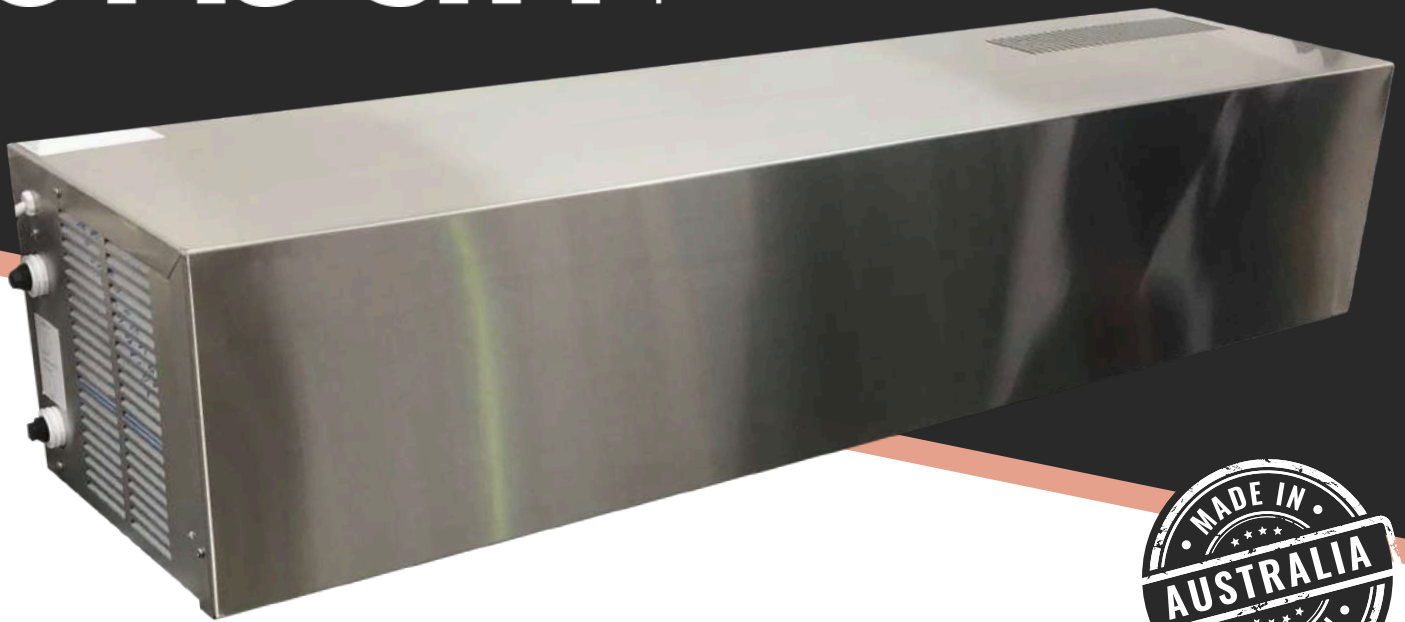

Refrigerated Water Chiller

to suit a 3 tap school drinking trough

These refrigerated water coolers are designed to be installed underneath a school drinking trough. It can be installed along with a new drinking trough or can be fitted underneath an existing drinking trough thus saving on the cost purchasing new troughs, faucets and plumbing installation.

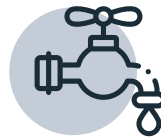

Water Supply
Mains Water Supply



Dimensions (mm)
Cabinet 850W, with Mounting bracket
950W x 340D x 280H (Boxed
Measurements 1010W x 370D x 310H)



Weight
38kgs (Boxed Weight 40kgs)



Cooling System
R134a refrigerant, compressor



Colour
Stainless Steel Cabinet



Power Supply
220/240volt, 50hz, 1ph, 2.6 amps,
395 watts, IP33

Description and Features

- + This is a wall mounted refrigerated water chiller.
- + It must be mounted horizontally.
- + Must not be installed inside a cupboard or an enclosed space.
- + This water cooler is fitted with a low ambient temperature control to help prevent the refrigeration system from running in cooler weather (21 degrees C or below) and extending the life of the refrigeration system. *Children don't need to be drinking cold water when the outside temperature is below 21 degrees C.*
- + All the electrical wiring is double insulated.
- + All water lines and fittings are insulated to prevent condensation.
- + Has a 10amp power plug top.
- + Will produce approximately 72 litres of cold water per hour.
- + Water fittings 15mm female thread (water in and water out).
- + Maximum working water pressure 700kpa.
- + The outside and inside panelling in stainless steel.
- + All the nuts, bolts and screws are stainless steel.
- + Has heavy gauge 6mm x 100mm x 250mm stainless steel wall mounting brackets.
- + A two year warranty on the refrigeration system.

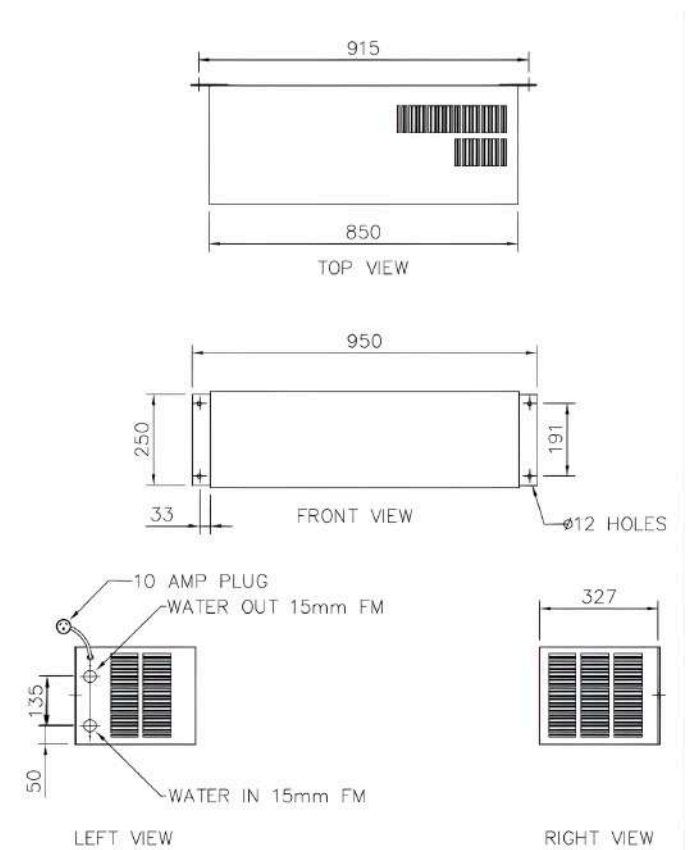

Please note: All specifications, dimensions, parameters and performances subject to change without notice.