

CARE AND MAINTENANCE

1. Regular washing down of the exterior surface will help prolong the lustre of the painted finish.
2. Painted fountains that become dull due to prolonged exposure to direct sunlight can be restored with an appropriate surface polish.
3. To maintain the exterior of the fountain carefully remove any loose surface deposits with a wet sponge. Use a soft (non abrasive) brush and dilute a solution of mild detergent (eg. PH-neutral liquid hand washing detergent in warm water (DO NOT use solvents) to remove dust, salt and other deposits. Rinse thoroughly with clean fresh water to remove residues. To remove any Tea Staining on Stainless Steel surfaces we recommend Drifter Hull cleaner and stain remover.
4. Do not use any solvents on the surface as this will adversely affect the longevity of the painted finish.
5. Surface scratches and inconsistencies can be touched up using Dulux touch up paint. Most colours can be matched.
6. We recommend the use of anti-seize paste on all external fixing bolts to maintain ease of access over long periods of time.
7. Check the fountain internal connections, water flow and all external access screws and fixing bolts regularly (every 3mths) to ensure they are tight.
8. In high debris areas (parks, children's playgrounds etc) where there may be sand or bark or a lot of leaf litter that may be placed in to the basin, check regularly and remove debris to prevent blocking of the basin or the waste outlet pipe.
9. After any interruption to the water supply, always flush the lines prior to reconnection to the fountain to prevent debris entering the valve.

WARRANTY

All Urban Fountains and Furniture outdoor drinking fountains are covered by a 2 year manufacturers guarantee against faulty materials and workmanship under normal wear and tear conditions.

All fountains are date stamped at the time of despatch.

This warranty will only apply under the following conditions:

- The fountain was installed in accordance with our installation instructions that are supplied with every fountain.
- The fountain was installed by a licensed plumber
- The water lines have been thoroughly flushed prior to connection to the fountain
- The fountain has not been tampered with or repaired in any way without obtaining prior approval from our factory specialists first.
- The fountain has been serviced and maintained as per our supplied instructions.

ATTENTION PLUMBERS

This fountain uses "Push In Fittings". Failure to release these fittings correctly will result in leakage.

These quick release fittings allow instant connection and disconnection without the use of spanners.

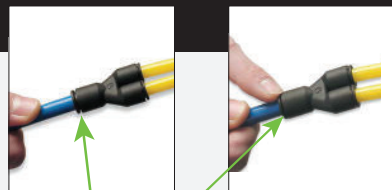

Push outer ring in to release tube from fitting

urban + Fountains Furniture

Drinking Fountains

Models: CF410

urban + Fountains Furniture

INSTALLATION, OPERATION AND MAINTENANCE INSTRUCTIONS

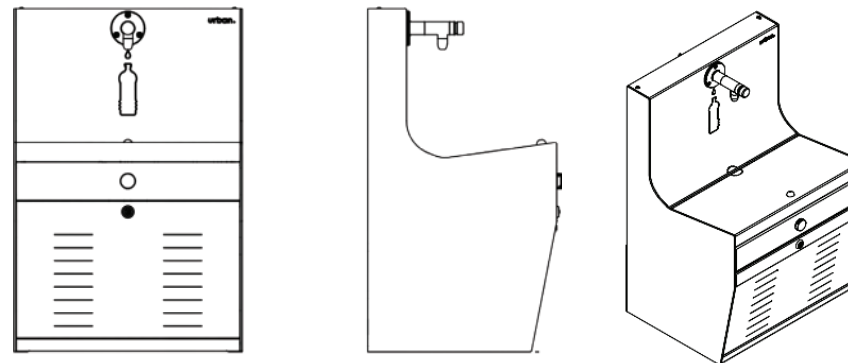

SPECIFICATIONS

- ▶ 1/2" bsb water inlet (15mm)
- ▶ 40mm waste outlet
- ▶ Maximum Temperature: 40°C
- ▶ Maximum Water Pressure: 500 kpa
- ▶ Complies with WMTS-105 Technical Specification: Appliances - Beverage dispensers and icemakers
- ▶ Complies with AS/NZS 4020 Testing of products in contact with drinking water

2 year
warranty



Lead Free

WM-080042
WMTS-105

CUSTOMER SERVICE

 **07 3382 7372**

 **office@urbanff.com.au**

 **07 3287 5598**

 **www.urbanff.com.au**



INSTALLATION

STOP! Please read all supplied information before installation.





















1. All UrbanFF Fountains must be installed by a qualified plumber and Qualified Electrician in accordance with National plumbing and drainage code AS/NZS 3500.1 and AS/NZS 3500.2 and Electrical AS3000 Regulations and any other local authority codes.
2. Wall mounted option. For wall mounted - **IMPORTANT** - Wall is to be assessed by structural engineer prior to installation to ensure load bearing is possible.
3. 240V single phase power is required along with mains water supply and waste outlet drainage.
4. Before Installation **FLUSH ALL EXTERNAL LINES** before connecting to fountain.
5. PLEASE NOTE: No Trap is supplied inside the fountain. Trap to be fitted externally by plumber.
6. Remove the fountain from the packaging preventing scratching and damage to the body of unit
7. Installation under shade preferable.
8. Please refer to provided installation drawings below for unit mounting details.
9. To access the 2 upper rear bolts for wall mounting, first remove the Right Side panel.
10. Remove the main trough which will give access to the 2 upper rear bolts. See Detail for fixing. Follow detailed drawings attached for wall installation and fixing.
11. Connect the 40mm waste outlet pipe to the waste water connection.
12. If you have not flushed the external water inlet pipes - do it now! Flushing the water inlet pipes from the mains supply before connecting to fountain will help prevent blockage by any debris that may be in the external pipes.
13. Connect water supply to 1/2" BSP inlet.
14. Test the bubbler and bottle filler by activating the button.
15. Incorrect installation will affect fountain performance. Urban Fountains and Furniture will not be responsible for defects that arise from incorrect installation.
16. All fountains have been checked for leaks as part of our quality assurance program and some droplets of water may be evident inside the packaging and/or unit. This is perfectly normal.
17. Refer to trouble shooting guide if you experience any problems or call UrbanFF 07 33827372
18. Check all connections and waste piping to ensure they are tight and secure

* **PLEASE REFER TO ANNEX A AND B**

TROUBLESHOOTING

There is restricted or no water flow?	Check the inlet lines for kinks in the tubing. Ensure the water supply valve is fully open. Check the water pressure regulator is open.
The water continues to drip / run after shutting off?	The most common cause of water not shutting off is a leaking valve and is due to the lines not being flushed adequately and debris getting in to the valve through the inlet and sitting on the rubber seals. To check the valve it will need to be removed. Please contact this office for details instructions to ensure this is done correctly.
The water flow is shooting over the top of the basin or is not high enough and trickling over the nozzle?	The water pressure is too high / low and needs to be adjusted via the water flow regulator so it flows in to the catchment area of the basin.
Leaking from the internal connections?	Check that they have been installed correctly. (all fountains are leak tested prior to leaving the factory). Have the push in fittings been pulled? (see instructions on how to connect and disconnect push in fittings). Is the water inlet connection tight?

SPARE PARTS

 8mm "Y" Fitting reorder code: PL1003	 Maintenance Tap reorder code: PL1034
 1/4" Legris Fitting reorder code: PL1030	 Bottle Filler reorder code: CM1125
 1/4 x 90° Fitting reorder code: ELB 1/4" x 90	 Urban Push tap with Paw print reorder code: CM1125-DT
 3/8 x 90° Fitting reorder code: ELB 3/8" x 90	 Enware Valve reorder code: DFX.A280.VALVE.ASSY
 8mm Straight Male -1/4" BSPT reorder code: PL1011	 Urban "T" Valve reorder code: CM1110
 8mm Straight Male -3/8" BSPT reorder code: PL1035	 Pressure Control Valve reorder code: PL1114
 5/16" Hose-Blue reorder code: PL1108	 15mm Mini Ball Valve reorder code: PL1019
 Self Returning Tap reorder code: PL1008	 Stop tap BUB268 reorder code: PL1031
 8mm Stem-1/4" BSPT reorder code: PL1000	 Urban Bubbler reorder code: CM1125-MG
 8mm Stem-3/8" BSPT reorder code: PL1001	 8mm Equal Elbow reorder code: PL1002
 1/2" Hollow Brass All Thread reorder code: PL1007	

urban Fountains + Furniture

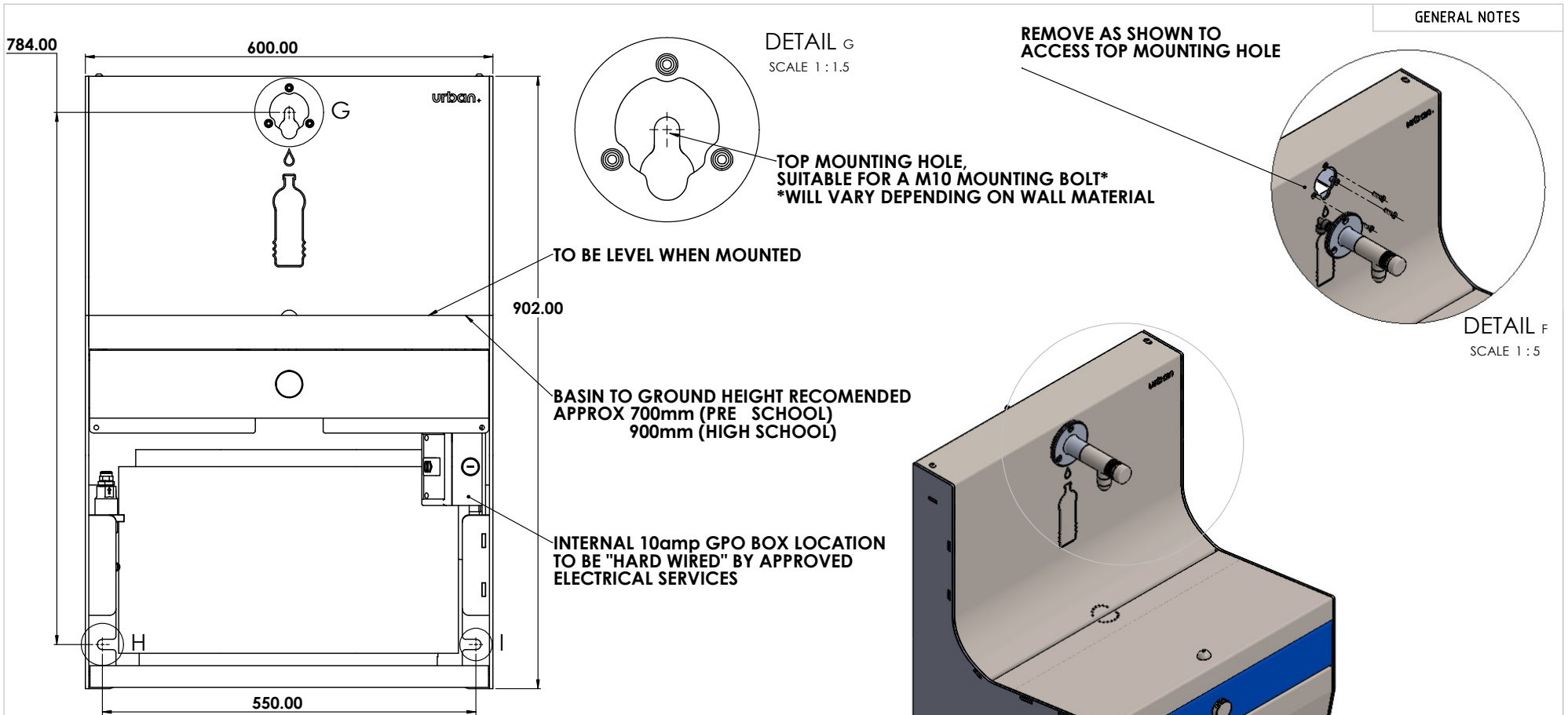

GENERAL NOTES

REMOVE ACCESS DOOR TO LOCATE LOWER MOUNTING HOLES
SUITS M10 MOUNTING BOLTS

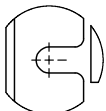

DETAIL H
SCALE 1:2



DETAIL I
SCALE 1:2

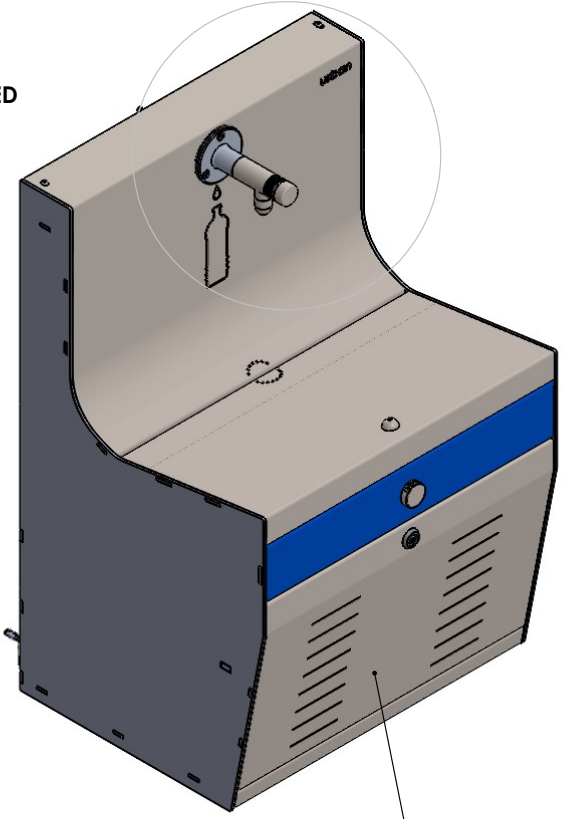

urban+

URBAN FOUNTAINS AND FURNITURE PTY LTD.
5 TELFORD CIRCUIT
YATALA, QUEENSLAND 4207
PH: (07) 3382 7372
FX: (07) 3287 5598
WWW.URBANFF.COM.AU
COPYRIGHT DISCLAIMER
THIS DRAWING, AND ALL THE INFORMATION ILLUSTRATED
HEREIN ARE SUBJECT TO COPYRIGHT. THIS DRAWING MAY
NOT BE COPIED IN PART OR WHOLE, WITHOUT PRIOR
WRITTEN CONSENT FROM URBAN FOUNTAINS AND FURNITURE
PTY LTD.

DO NOT SCALE DWG, IF IN DOUBT, ASK!

UNITS OF MEASURE
ALL DIMENSIONS ARE IN MILLIMETERS U.O.M. **MM**

DRAWN BY: N.FERGUSON
DATE: 12/11/2025
SCALE: 1:10
SHEETS: 2

DRAWING TITLE: CF410 CHILLER MOUNTING DETAILS
DRAWING NUMBER: CF410-CMD
REVISION: 00

MATERIAL	FINISH

REMOVE ACCESS DOOR TO GET TO MOUNTING HOLES

REVISION	DESCRIPTION	DRAWN BY	DATE
00	ISSUED FOR REVIEW	G.ALLAN	11.11.2025

**WASTE TROUGH OUTLET DIRECTION CAN BE REVERSED IF REQUIRED
*TO BE DETERMINED & CHANGED PRIOR TO MOUNTING ONTO THE WALL***

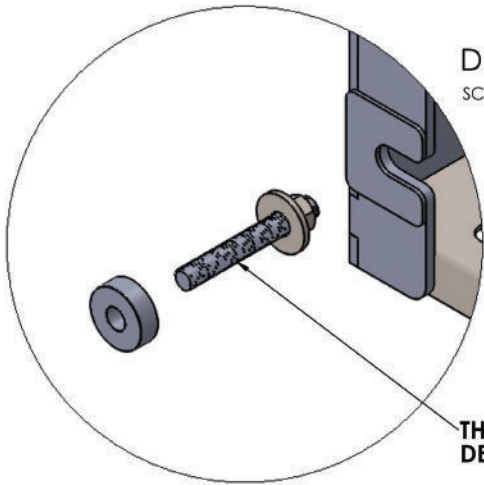

DETAIL J
SCALE 1:1.5

**THREAD LENGTH/METHODOLOGY TO BE DETERMINED ON SITE
DEPENDING ON WALL MATERIAL/LOCATION ETC**

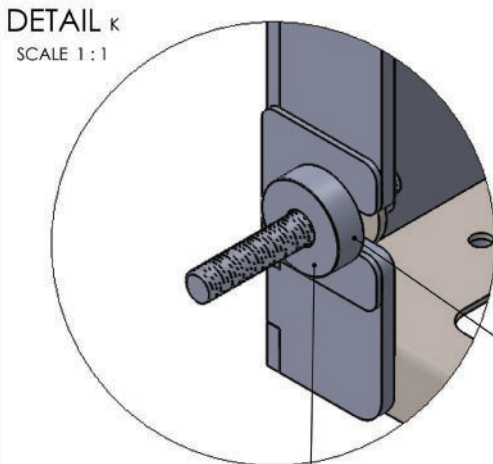

DETAIL K
SCALE 1:1

MOUNT AS SHOWN

OPTIONAL WASTE OUTLET PORTS

**SUPPLIED WALL SPACERS WASHERS
(3 of) TO BE USED WITH M10 BOLTS**

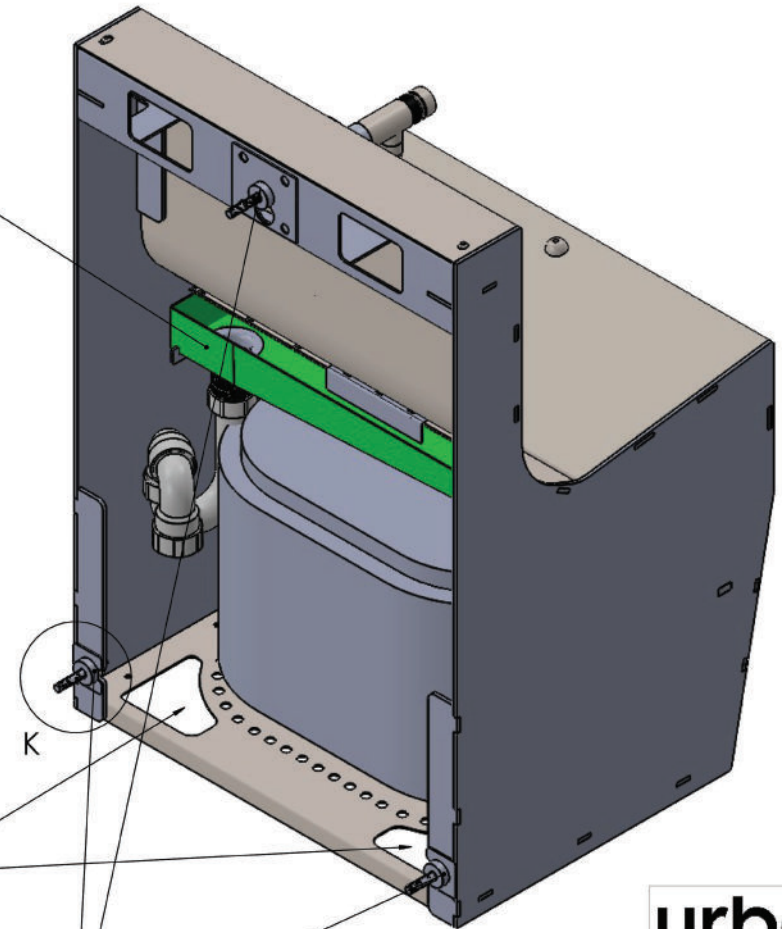

urban +

URBAN FOUNTAINS AND FURNITURE PTY LTD.
5 TELFORD CIRCUIT
YATALA, QUEENSLAND 4207
PH: (07) 3382 7372
FX: (07) 3287 5598
WWW.URBANFF.COM.AU
COPYRIGHT DISCLAIMER
THIS DRAWING, AND ALL THE INFORMATION ILLUSTRATED
HEREIN ARE SUBJECT TO COPYRIGHT. THIS DRAWING MAY
NOT BE COPIED IN PART OR WHOLE, WITHOUT PRIOR
WRITTEN CONSENT FROM URBAN FOUNTAINS AND FURNITURE
PTY LTD.

DO NOT SCALE DWG, IF IN DOUBT, ASK!

UNITS OF MEASURE
ALL DIMENSIONS ARE IN MILLIMETERS U.O.M. **MM**

DRAWN BY **N.FERGUSON** DATE **12/11/2025**
SCALE **1:10** SHEETS **2**

DRAWING TITLE
CF410 CHILLER MOUNTING DETAILS

DRAWING NUMBER **CF410-CMD** REVISION **00**

MATERIAL	FINISH

REVISION	DESCRIPTION	DRAWN BY	DATE
00	ISSUED FOR REVIEW	G.ALLAN	11.11.2025