

ARCHITECTURAL FOUNTAINS | CF410 CHILLED OUTDOOR DRINKING FOUNTAIN | SPECIFICATION SHEET

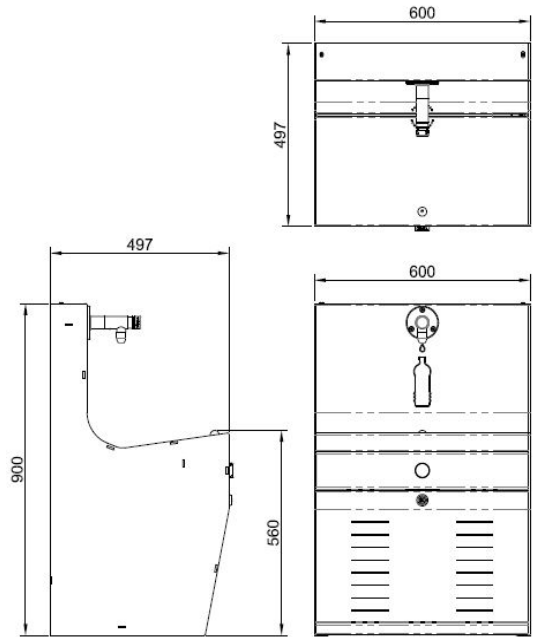

MODEL

Model: CF410 Chilled Outdoor Drinking Fountain

SKU: DFCF410 DFCF410_P (with optional side panel signage)

DIMENSIONS

Total Height: 900mm

Width: 600mm

Depth: 497mm

CERTIFICATIONS



FEATURES

- + Stainless Steel Modular Construction
- + 1x Bottle Filler
- + 1x Drinking Bubblers
- + 316 S/S Trough and Fixings
- + 5L Holding tank (Chilled Water)
- + Easy Activated push buttons
- + Wall Mounted (height can vary to suit requirements)
- + Australian Made
- + Vandal resistant
- + Easy Installation
- + Compressor PW5.5VK, 148W
- + Chilled water flow rate: 19L/Hr

OPTIONS

- + Available in 3, tap or 2 tap units
- + Different Powder coated colour options for button plate
- + Optional Signage or Logo Panel with branding for side panels

POPULAR COLOURS



COAST



STORM



DESERT



FLAME



LEAF



EVERGREEN



MONUMENT



STAINLESS